

AdVance® RTK

Competitive Analysis

Abstract

This paper summarizes the results of field tests conducted by NovAtel to compare the performance of AdVance RTK in real world conditions that GNSS users often encounter. The paper demonstrates that NovAtel AdVance RTK exceeds the performance of competitor RTK products in the following common conditions:

- Medium baseline – open sky
- Medium baseline – high multipath
- Long baseline – high ionosphere activity
- Short baseline – forest canopy

The results show that NovAtel AdVance RTK provides consistent, highly accurate and available RTK positioning for maximum productivity in real-world GNSS conditions.

Introduction

To perform RTK positioning, users place a GNSS base receiver over a known point to measure GNSS carrier-phase errors. RTK corrections are transmitted to a GNSS rover receiver which then performs precise RTK positioning by removing GNSS propagation errors and initializing or “fixing” the carrier phase solution. There is only one correct carrier-phase combination. Once the RTK engine “fixes” the solution correctly, continuous centimetre-level positioning is achieved provided the satellite signals are not lost. If the RTK engine fixes incorrectly, the positioning accuracy may be reported as centimetre-level when in fact, it may be several decimetres or metres in error.

RTK performance varies depending on the environment in which the work is being performed. In open-sky conditions, the number of observable satellites is high and the satellite signals are clean. In this case, RTK calculations are typically straightforward as long as the baseline length is within the limits of the RTK engine. However, GNSS users are not always working in ideal, open-sky conditions. Instead, they often work around buildings, bridges, vehicles, trees and other obstructions which add significant measurement errors to GNSS signals. In addition, GNSS users are stretching the baseline lengths over which RTK engines can “fix” in real world conditions, which also increases the challenge of RTK positioning.

NovAtel has recently carried out extensive testing that compares the performance of our AdVance RTK engine with a number of competitor products. The test methodology and environments were selected to be representative of real-world use cases and conditions in which users regularly operate:

- Clear-sky
- High-multipath
- High-ionosphere, long-baseline
- Canopy

The performance of the RTK engines was measured using the following criteria:

- RTK accuracy – Reliable centimetre-level accuracy is needed for high precision applications
- RTK availability – RTK fixes must be readily available in the work environment
- RTK initialization time – Faster RTK fixing leads to more productivity in the field

This white paper describes the test set-up and methodology, then presents, interprets and summarizes the results.

Test Set-up and Methodology

The RTK test set-up was designed to remove biases between receivers to isolate RTK performance:

- All receivers use identical RTK corrections
- All receivers use the same GNSS antenna, for identical antenna placement
- GNSS antenna signal power is calibrated for each receiver
- GNSS antenna signal is connected/disconnected at precisely the same time

RTK corrections were transmitted to the rover receivers via GPRS/NTRIP to allow long baseline testing. The test set-up is shown in **Figure 1**.

The RTK tests were designed to simulate how users work with GNSS receivers in the field. Users may experience frequent loss of GNSS signals when traveling under bridges, and around buildings and other obstructions. To simulate this, the RTK tests force a loss of signal at regular intervals by disconnecting the GNSS antenna for 5 to 30 seconds then reconnecting for 295 to 395 seconds. This allows each receiver to fix their RTK solution and collect position data until the next signal outage. This is a typical scenario when GNSS receivers are used for survey work, for example.

Test Results

Medium Baseline – Open Sky Test Results

A 14 km baseline was selected for the open-sky RTK test. The base and rover GNSS receivers and antennas were placed on building rooftops with minimal multipath for ideal GNSS signal conditions. The results of the medium-baseline open-sky test are documented in **Figures 2** through **4** and **Tables 1** and **2**.

Figure 1 AdVance RTK Competitive Analysis - Test Set-up

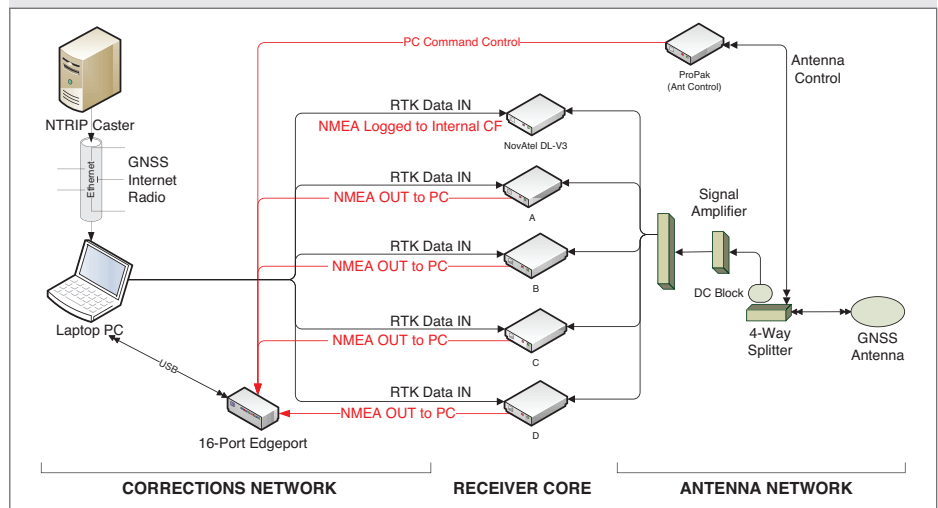

Figure 2 Horizontal Position Error Scatter – 14 km Baseline – Open Sky

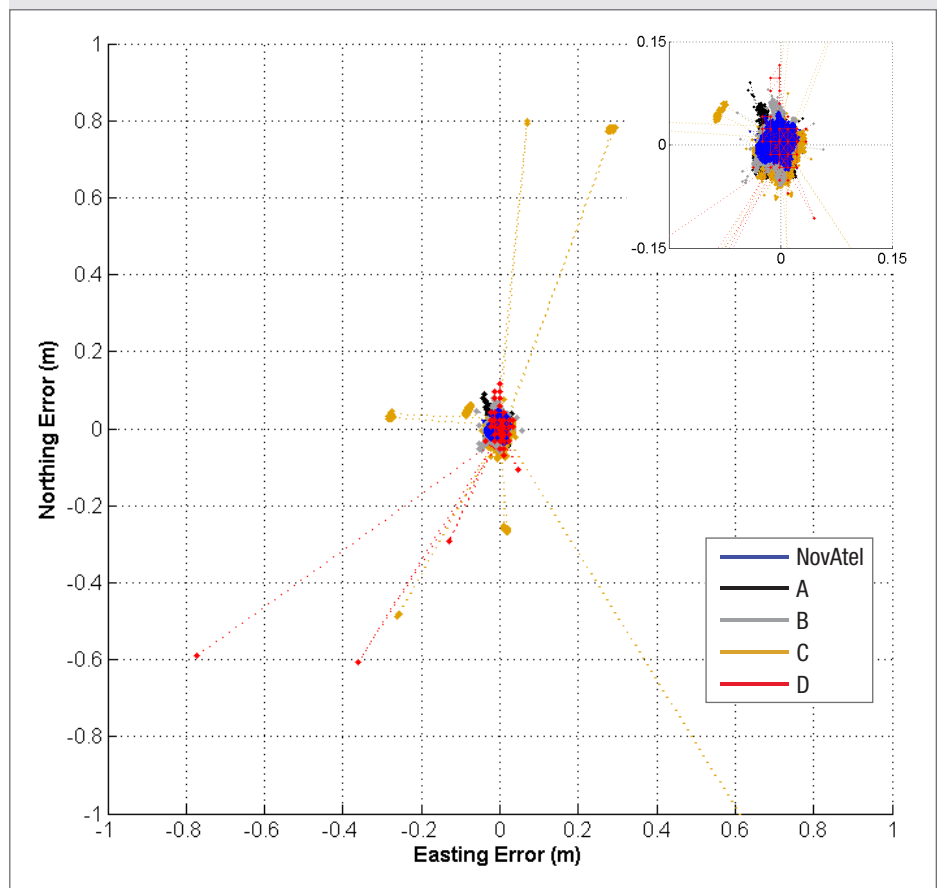
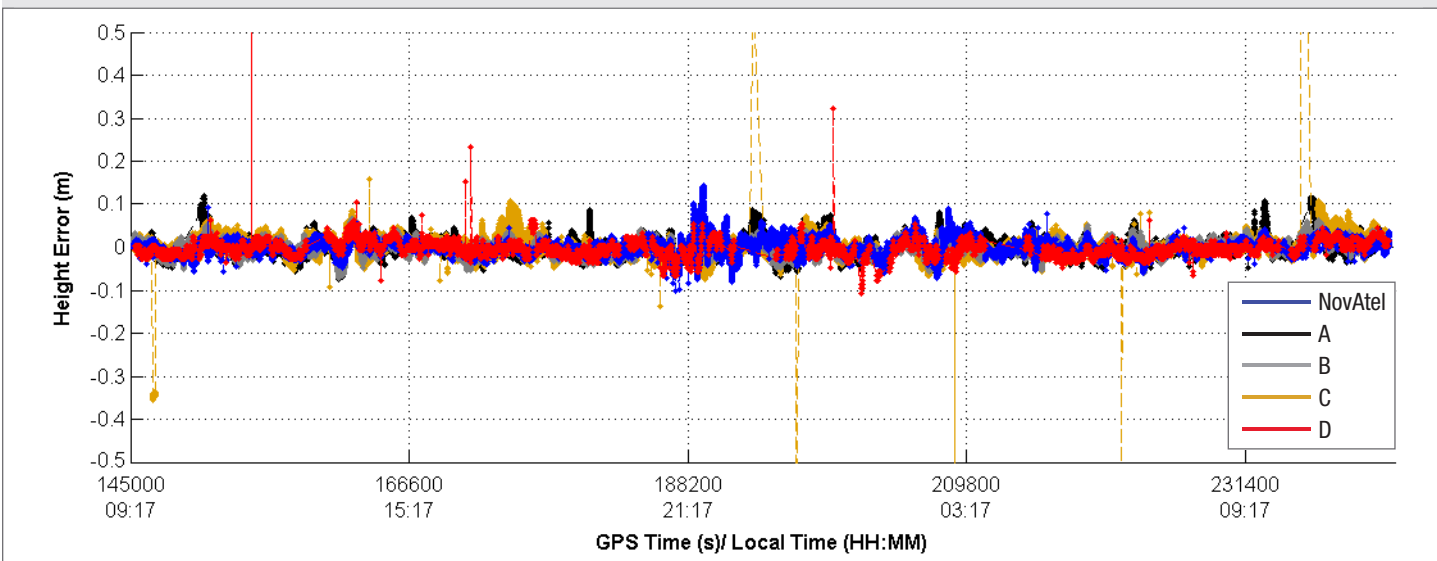

Table 1 Position Accuracy Statistics – 14 km Baseline – Open Sky

Receiver	Horizontal Error			Height Error		
	Max (m)	Mean (m)	RMS (m)	Max-Min (m)	Mean (m)	RMS (m)
NovAtel	0.051	0.011	0.013	0.245	0.000	0.018
A	0.100	0.013	0.016	0.195	0.001	0.020
B	0.082	0.014	0.017	0.136	-0.001	0.018
C	2.624	0.016	0.055	4.581	0.000	0.072
D	0.971	0.014	0.018	1.740	-0.003	0.018

Figure 3 Vertical Position Error – 14 km Baseline – Open Sky



As shown in **Tables 1** and **2**, NovAtel yielded the highest horizontal and vertical accuracy and provided the most fixed solutions. Although not as accurate, competitors A, B and D showed positioning accuracy approaching that of NovAtel. Competitors C and D both produced occasional horizontal and vertical position outliers.

As shown in **Table 2**, NovAtel also demonstrated the fastest time to fix with 100% success rate for RTK initialization. RTK fixing was less consistent with Competitors A, B and D as approximately 10% of initialization attempts were lengthy or unsuccessful. Competitor C time to fix was the longest and least consistent.

Figure 4 Time to Fix Percentage - 14 km Baseline – Open Sky

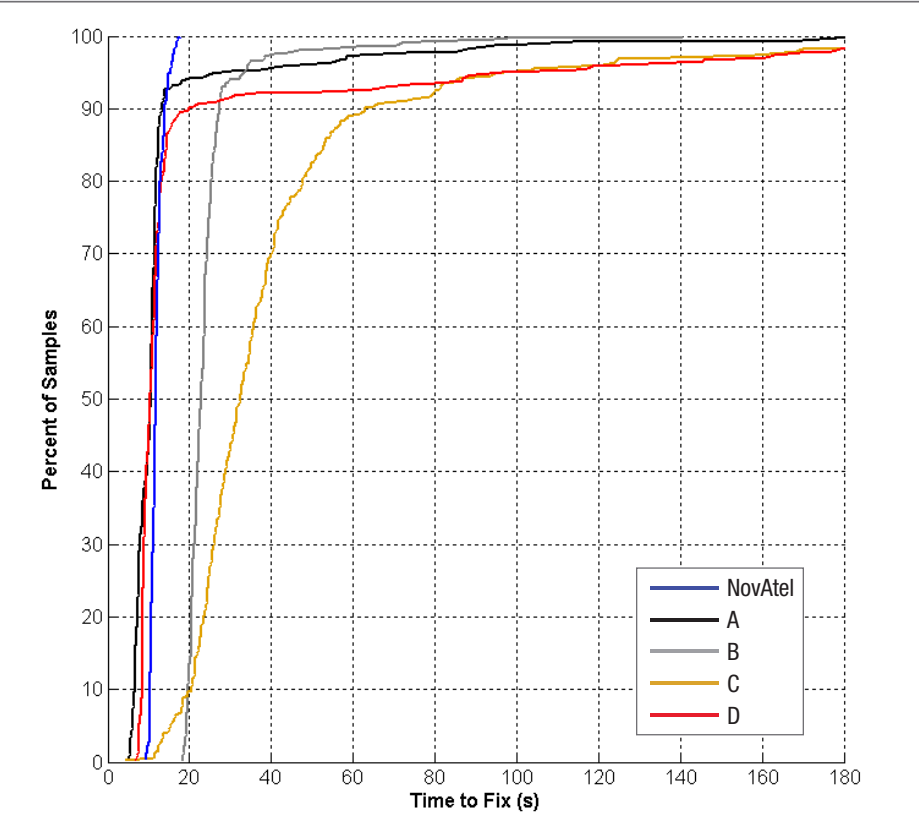

Table 2 Time to Fix – 14 km Baseline – Open Sky

Receiver	RTK Fix Success	Min Fix Time (s)	Max Fix Time (s)	Mean Fix Time (s)	# Fixed Solutions
NovAtel	405/405	9	18	12.0	89886
A	392/405	5	185	13.6	85817
B	399/405	18	141	24.5	83621
C	383/405	4	229	40.9	73393
D	342/405	7	233	20.9	72689

Medium Baseline – High Multipath Test Results

GNSS users are rarely subject to the ideal conditions found in the open sky test. Vehicles, buildings, trees and other obstructions limit the number of visible satellites. In addition, local structures also reflect GNSS satellite signals, a phenomenon referred to as multipath propagation. These reflected signals interfere with the direct signal, degrading the GNSS measurement quality.

Multipath errors are the most difficult to detect and isolate due to their localized nature - the multipath at the base is always different than the multipath at the rover. This may cause difficulties fixing to the correct RTK solution if multipath is not addressed properly.

To emphasize the effect of multipath error on RTK performance the same baseline used for the open sky test was used for the multipath test; however, local reflectors were placed around the antenna. The results are shown in **Figures 6, 7 and 8** and in **Tables 3 and 4**.

Figure 5 Typical Multipath Environment



Figure 6 Horizontal Position Error Scatter – 14 km Baseline – High Multipath

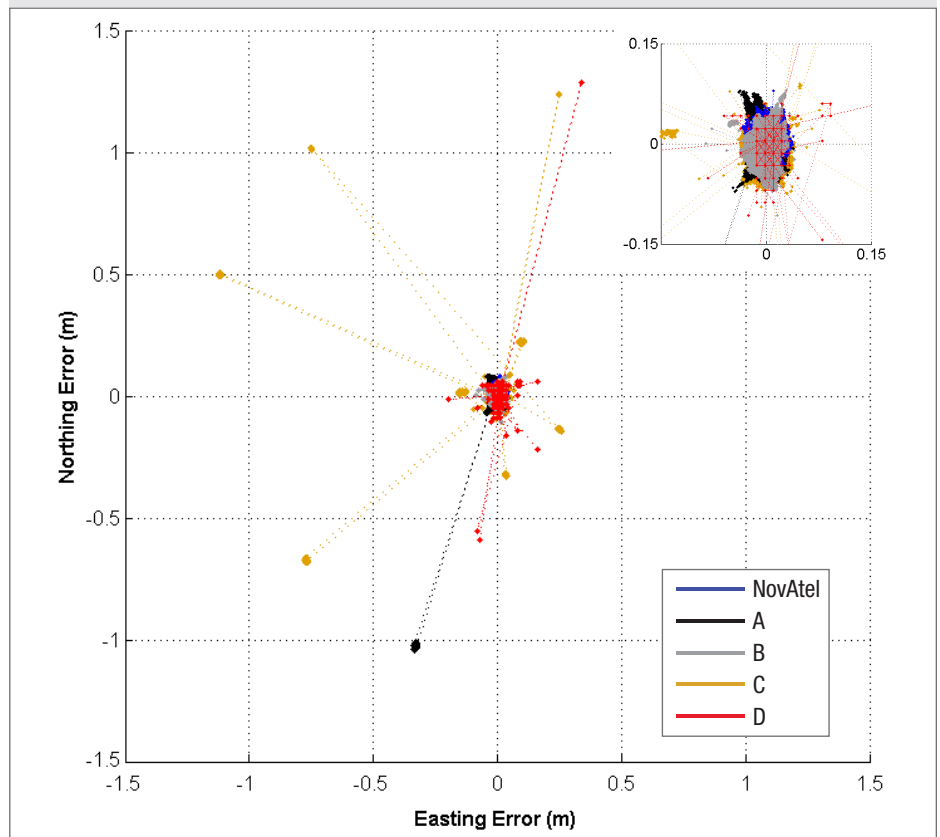
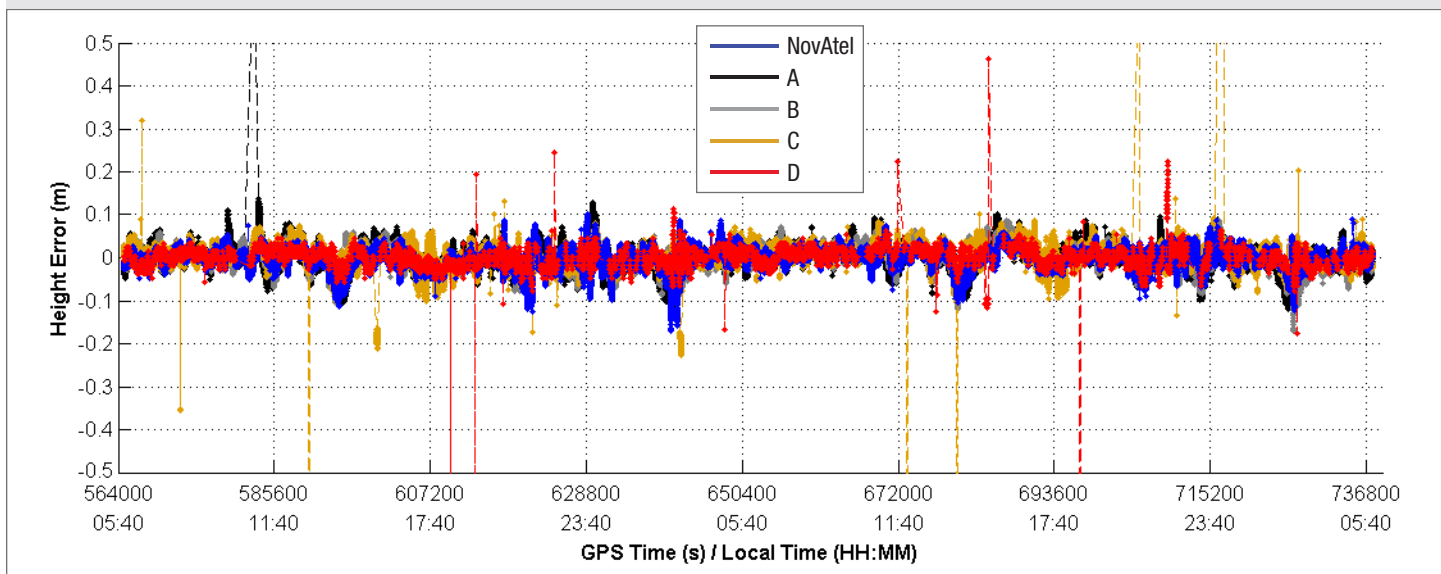

Table 3 Horizontal Position Error Scatter – 14 km Baseline – High Multipath

Receiver	Horizontal Error			Height Error		
	Max (m)	Mean (m)	RMS (m)	Max-Min (m)	Mean (m)	RMS (m)
NovAtel	0.080	0.013	0.015	0.271	-0.002	0.023
A	1.096	0.015	0.036	0.820	0.000	0.033
B	0.108	0.016	0.019	0.258	-0.001	0.027
C	1.266	0.019	0.058	5.504	0.001	0.109
D	1.327	0.015	0.019	2.540	0.001	0.021

Figure 7 Vertical Position Error – 14 km Baseline – High Multipath



As shown in **Tables 3** and **4**, NovAtel yielded the highest accuracy and the most fixed solutions. Competitor B and D produced similar accuracy, however, Competitor D produced the occasional outlier (shown in **Figures 6** and **7**). Competitors A and C also produced occasional positioning outliers and lower horizontal and vertical accuracy.

As shown in **Table 4**, NovAtel achieved near-100% success rate, with a significantly faster initialization time than its competitors. Competitors A and D initialization performance degraded significantly when multipath was added to the scenario. As illustrated in **Figure 8**, 20% of initialization attempts were lengthy or unsuccessful, compared with 10% in the open sky test.

Figure 8 Time to Fix Percentage - 14 km Baseline – High Multipath

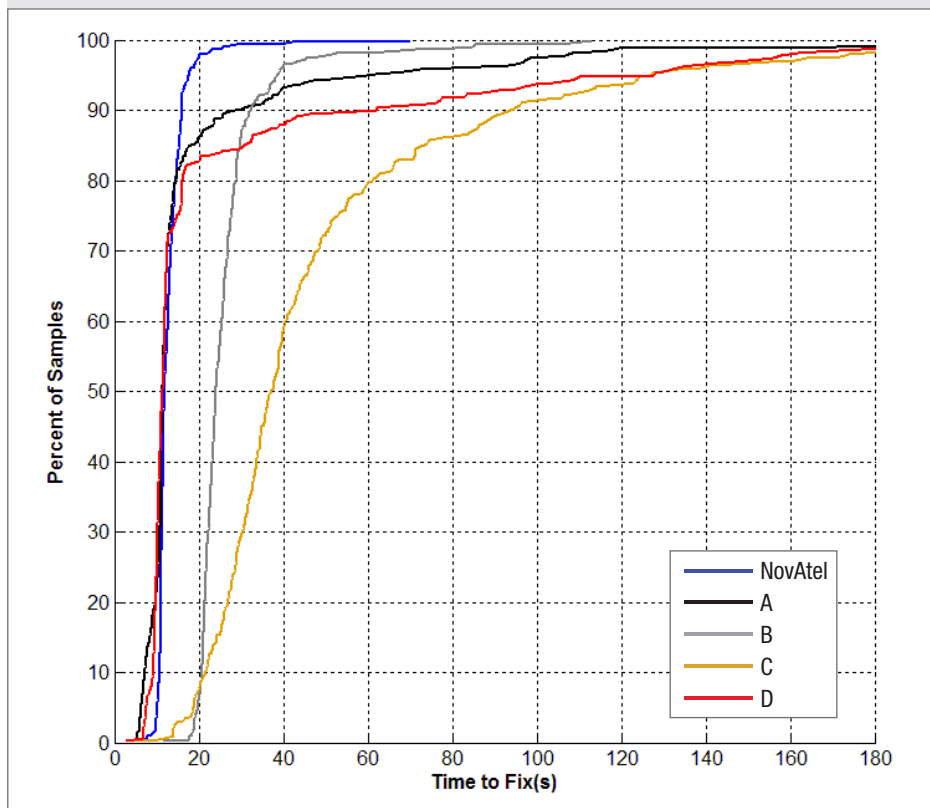

Table 4 Time to Fix – 14 km Baseline – High Multipath

Receiver	RTK Fix Success	Min Fix Time (s)	Max Fix Time (s)	Mean Fix Time (s)	# Fixed Solutions
NovAtel	719/720	5	70	13.0	158577
A	694/720	3	224	20.1	146254
B	714/720	12	113	26.5	147955
C	627/720	10	231	52.5	112707
D	574/720	3	232	27.7	117981

Long Baseline - High Ionosphere Test Results

During the course of a day, varying degrees of solar activity cause the concentration of charged particles in the ionosphere to change, as shown in **Figure 9**. As baseline length increases, the effect of the ionosphere on signal propagation at the base and rover becomes less correlated. The ability to mitigate the effect of the ionosphere is critical in RTK positioning as it extends the baseline range over which users are able to work.

The ionosphere may affect GNSS receivers at any time but the most significant affects to RTK are seen between 9:00 and 18:00, the typical working hours of most GNSS users. During this time RTK baseline lengths may be limited to 10 km or less for manufacturers with RTK engines unable to cope with high-ionosphere activity. Solution accuracy and availability will inevitably be limited at longer baseline lengths lowering the productivity of GNSS users.

The following test was performed using a 28 km baseline with open sky conditions during significant ionospheric activity. The results of the test, which lasted 18 hours, are shown in **Figures 10, 11** and **12** and **Tables 5** and **6**.

Figure 9 Ionospheric TEC Map

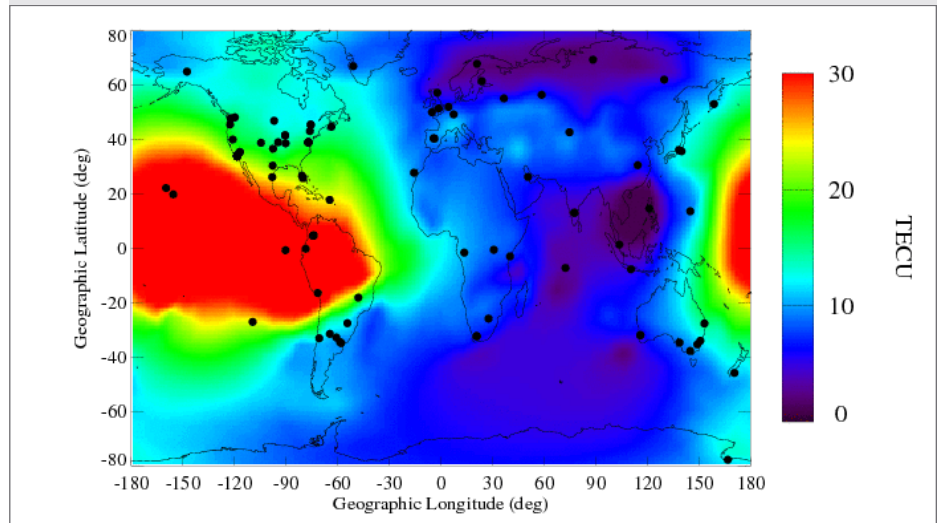

Figure 10 Horizontal Position Error Scatter – 28 km Baseline – High Ionosphere

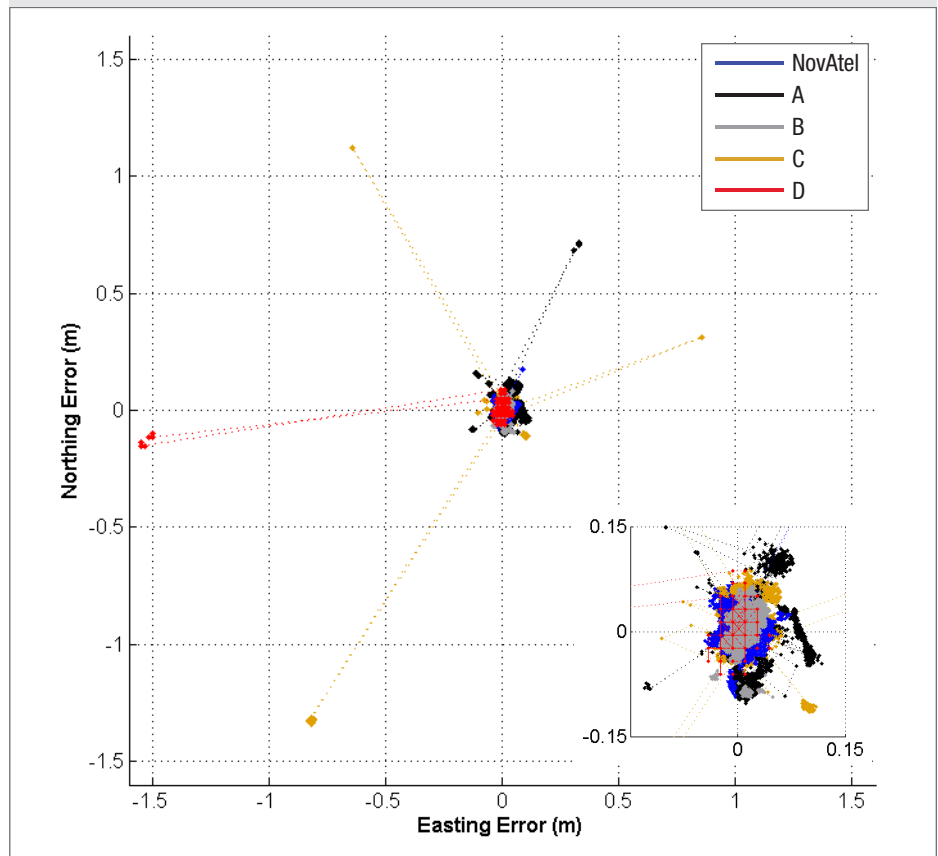
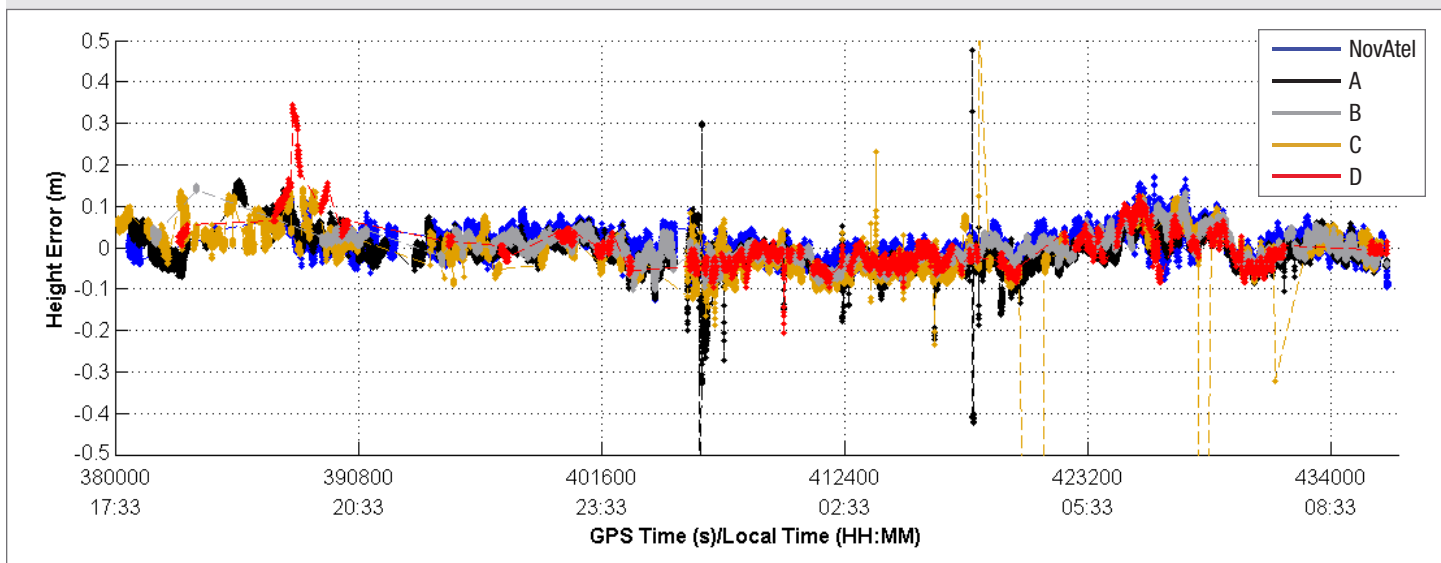

Table 5 Horizontal Position Error Scatter – 28 km Baseline – High Ionosphere

Receiver	Horizontal Error			Height Error		
	Max (m)	Mean (m)	RMS (m)	Max-Min (m)	Mean (m)	RMS (m)
NovAtel	0.196	0.019	0.022	0.296	0.005	0.034
A	0.788	0.022	0.031	2.034	-0.009	0.049
B	0.106	0.018	0.022	0.251	0.000	0.037
C	1.569	0.029	0.083	3.963	-0.014	0.176
D	1.556	0.054	0.211	0.550	0.002	0.060

Figure 11 Vertical Position Error – 28 km Baseline – High Ionosphere



The test started at approximately 14:00 at which time solar activity is at its peak. As shown in **Figure 11**, none of the receivers included in the test could provide a fixed RTK solution until 17:33.

As shown in **Table 5**, Competitor B yielded similar accuracy as NovAtel, however, provided less RTK fixed solutions (**Table 6**). Competitor A provided the highest number of fixed RTK solutions, however, it was slightly less accurate than NovAtel and produced occasional outliers. Competitors C and D had problems fixing their RTK solution and when fixed provided less accurate results than the rest.

Competitor A proved to have the fastest initialization time and success rate, but occasionally fixed incorrectly. NovAtel was the second fastest followed by Competitor B, however, 10% of initializations for all three leading competitor receivers were lengthy or unsuccessful (**Figure 12**). Competitors C and D had difficulties fixing throughout the test and provided the slowest time to fix their RTK solution.

Figure 12 Time to Fix Percentage - 28 km Baseline – High Ionosphere

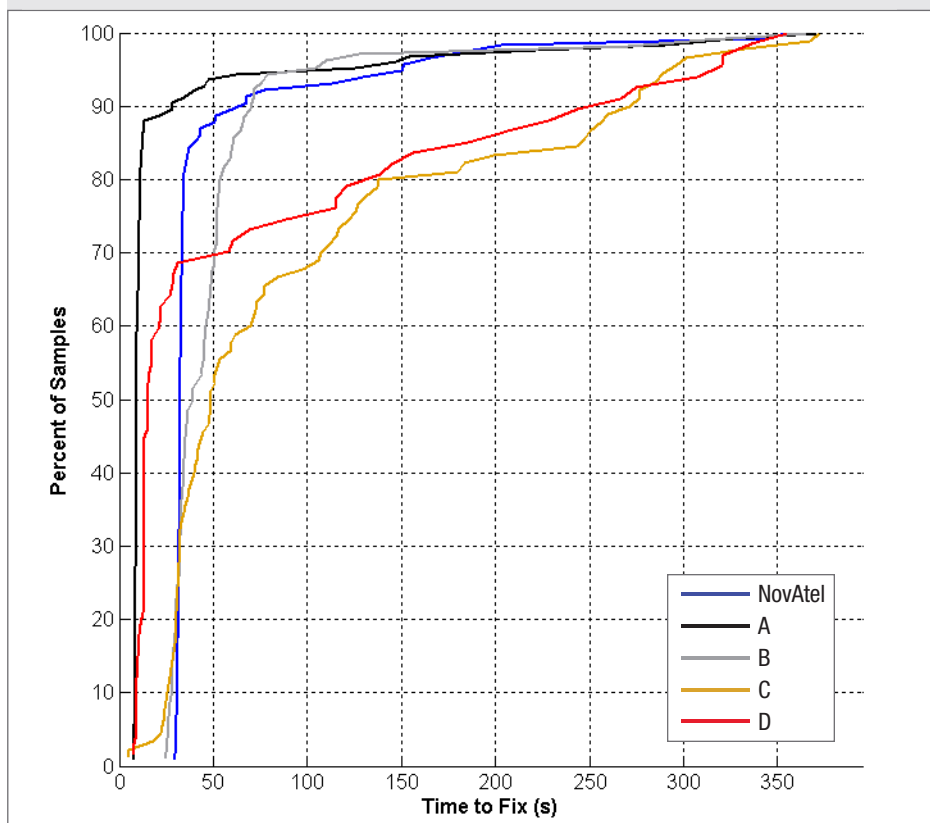

Table 6 Time to Fix Percentage – 14 km Baseline – High Ionosphere

Receiver	RTK Fix Success	Min Fix Time (s)	Max Fix Time (s)	Mean Fix Time (s)	# Fixed Solutions
NovAtel	115/134	29	355	47.3	39371
A	125/134	8	370	23.9	45808
B	105/134	24	366	51.8	35566
C	90/134	5	372	96.9	25003
D	67/134	8	355	71.5	20734

Short Baseline – Canopy Test Results

Similar to high-multipath environments, operating under forest canopy causes GNSS signals to be blocked, attenuated or reflected. This causes limited satellite signal availability, and signals that are tracked will typically be weak and of poor quality. This makes RTK positioning in forests very difficult and may result in limited RTK fixing and degraded accuracy.

A 3 km baseline test was performed in a forest to show the effects of RTK positioning under canopy. The antenna location for the test is shown in **Figure 13**. This static test spanned 45 hours and included 840 fix attempts.

Figure 13 Typical Canopy Environment



Figure 14 Horizontal Position Error Scatter – 3 km Baseline – Canopy Test

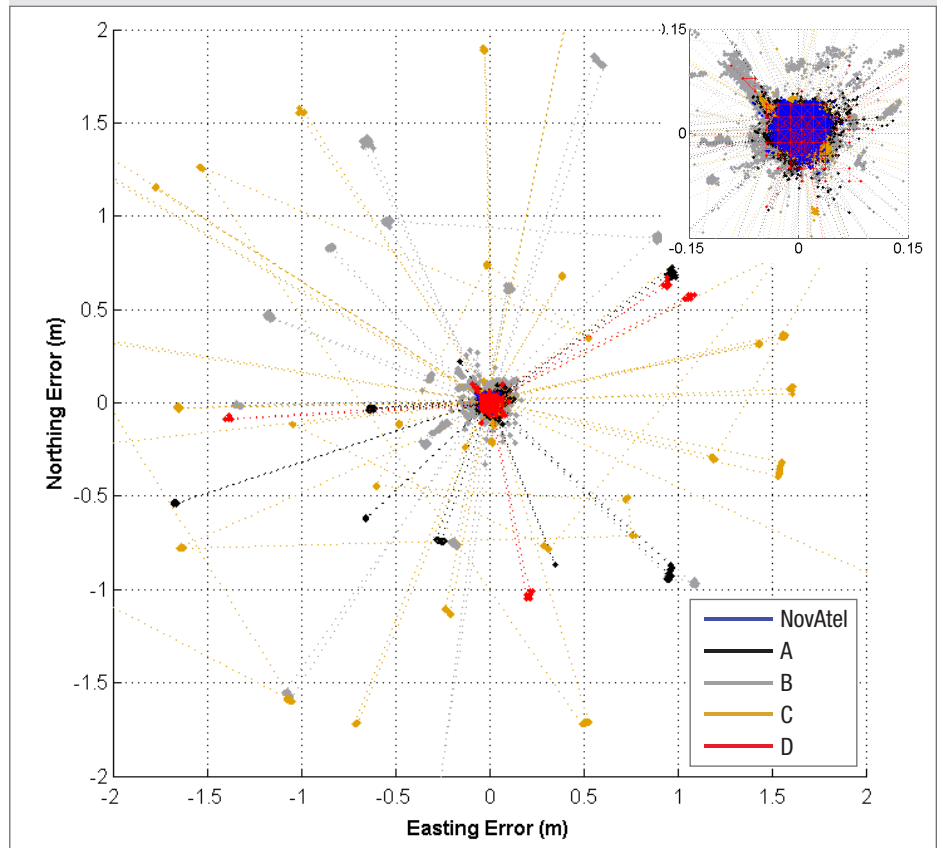
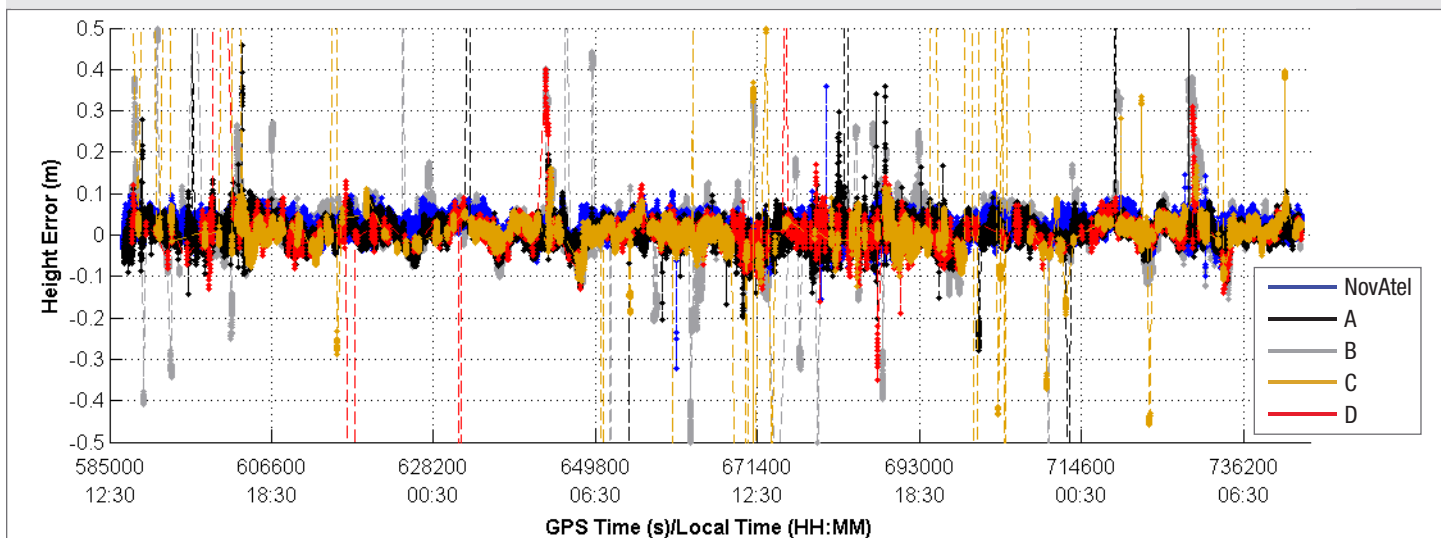

Table 7 Horizontal Position Error Scatter – 3 km Baseline – Canopy Test

Receiver	Horizontal Error			Height Error		
	Max (m)	Mean (m)	RMS (m)	Max-Min (m)	Mean (m)	RMS (m)
NovAtel	0.077	0.014	0.016	0.683	0.019	0.029
A	1.763	0.017	0.056	8.057	0.010	0.080
B	2.207	0.045	0.182	3.515	0.021	0.137
C	4.167	0.101	0.449	8.988	0.017	0.518
D	1.403	0.029	0.116	4.290	0.001	0.205

Figure 15 Vertical Position Error – 3 km Baseline – Canopy Test



As shown in **Figures 14** through **16**, and **Tables 7** and **8**, RTK fixing was more difficult for all receivers. NovAtel provided the most RTK fixed solutions with the highest accuracy. NovAtel also was the only receiver that did not provide any outlier RTK positions. Competitors A and B provided roughly 20 to 25% fewer solutions than NovAtel with lower accuracy and the occasional outlier. Competitors C and D provided less than half the solutions than NovAtel and with the lowest accuracy.

85% of NovAtel’s RTK initializations were achieved in less than 20 seconds; however, due to poor satellite geometry the remaining 15% of fixes were lengthier. The NovAtel receiver only failed to achieve an RTK solution in 1 of 840 iterations (0.1%). Competitor A could only fix 60% of its RTK initializations in less than 20 seconds, while Competitor D only 36%. Competitors B and C had the slowest time to fix. On average, NovAtel was significantly faster and more successful at fixing RTK position under canopy.

Figure 16 Time to Fix Percentage - 3 km Baseline – Canopy Test

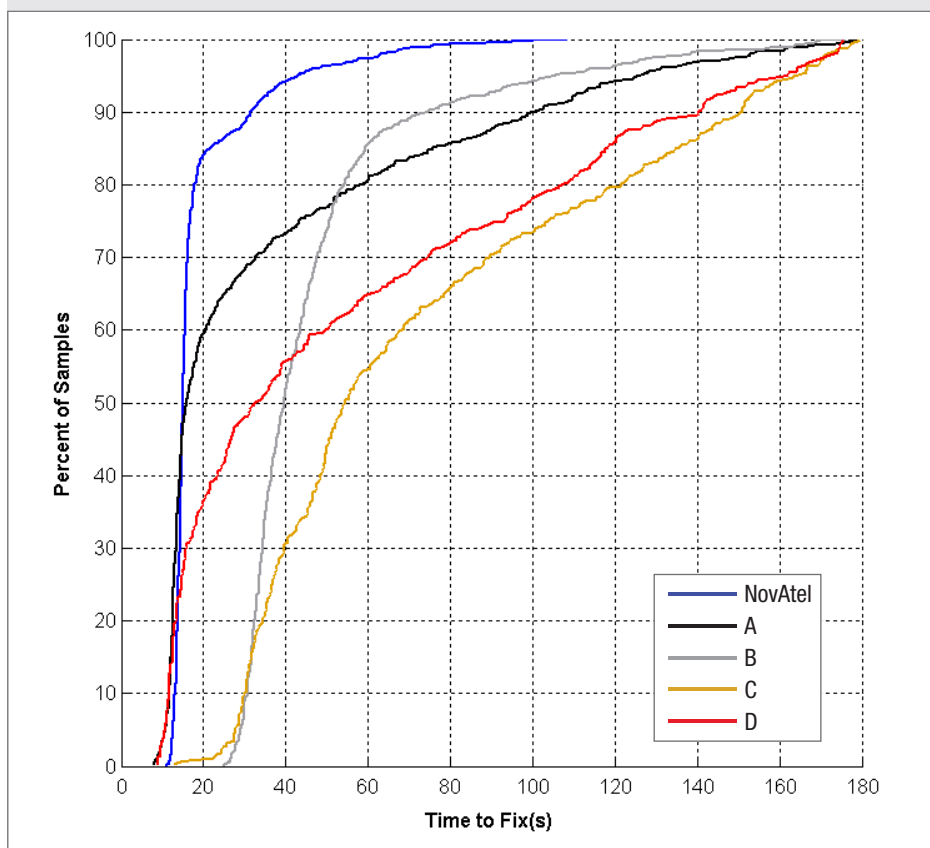

Table 8 Time to Fix Percentage – 14 km Baseline – High Ionosphere

Receiver	RTK Fix Success	Min Fix Time (s)	Max Fix Time (s)	Mean Fix Time (s)	# Fixed Solutions
NovAtel	839/840	11	109	19.0	135728
A	760/840	8	179	36.1	107368
B	761/840	25	176	47.8	101234
C	377/840	13	180	73.4	36750
D	392/840	9	176	55.6	48661

Summary

Effective RTK testing was conducted by eliminating biases to isolate RTK performance in terms of accuracy, availability and initialization time. Test methods were used to simulate typical working behaviour of GNSS users by forcing RTK initialization at frequent intervals. This measured not only the accuracy of RTK positioning, but also the initialization time and success rate of each competitor. Tests were conducted to determine how each GNSS manufacturer performs when subject to real world conditions.

Medium-baseline open-sky testing showed that NovAtel was the most accurate and provided the most fixed solutions with the quickest time to fix. However, Competitor A and B showed performance that approached that of NovAtel, while Competitors C and D provided lower accuracy with occasional outliers. Repeating the test with the same set-up but introducing multipath reflectors demonstrated that NovAtel delivered similar performance as in the open-sky test - consistently accurate and widely available RTK solutions. Competitor B had similar RTK

accuracy as NovAtel, but on average took twice as long to fix. Competitors A, C and D all produced outliers and showed a slower time to fix. Performing a long-baseline high-ionsphere test showed that Competitor B and NovAtel had similar high accuracy; however, NovAtel provided more RTK fixed solutions and a faster time to fix. Competitor A provided the most RTK fixed solutions but, similar to Competitors C and D, provided less accuracy than NovAtel and Competitor B with the occasional incorrect fix. A canopy test performed at 3 km from the RTK base showed that NovAtel provided the highest accuracy and fastest initialization performance. The other competitors provided limited solutions with less accuracy and occasional wrong fixes.

The rigorous RTK performance testing outlined in this paper shows that NovAtel AdVance RTK provides consistent, highly accurate and available RTK positioning for real-world GNSS conditions. This ensures that users may maximize their productivity when using AdVance RTK for their high accuracy RTK positioning.



novatel.com

sales@novatel.com

1-800-NOVATEL (U.S. and Canada)
or 403-295-4900

Europe 44-1993-85-24-36

SE Asia and Australia 61-400-833-601